

# AOC

# Clean desk, full motion



## Monitor arm stand

### AM406 series

- Aluminum Alloy Structure
- Durable Mechanical Spring
- Two Mounting Options
- Two Colors Options



White



Gray

- Full Range of Motion
- Optimized Tilting Structure
- Cable Management

[www.aoc.com](http://www.aoc.com)

vision at **Heart**

## ► Features

### Durable Mechanical Spring

More stable, safe and durable

A mechanical spring tensioning system is built into the upper arm to match the weight of the monitor. More than 30,000 exercise tests, safer and stronger.



### Full Range of Motion

Position your monitor with ergonomic comfort

It's easy to find the right viewing angle and position via arm extension, height adjustment, vertical tilt, horizontal swivel, and landscape or portrait rotation.

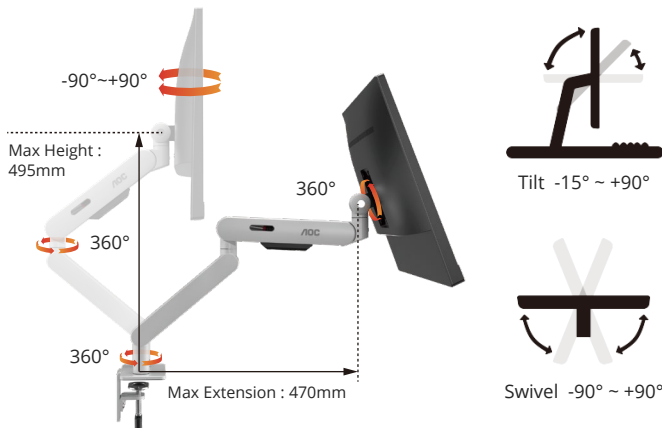

### Two Mounting Options

Free up your desktop with two mounting options

Two mounting options are available. please choose the clamp installation or the grommet hole installation base on your preference.

**Attention:** the thickness of the desktop should be from 15mm to 80mm.



### Cable Management

Keep cables hidden and organized

Integrated cable management conceals inside provide clean, neat and clutter-free appearance.



### Optimized Tilting Structure

Prevent the heavy display from bowing

The head connector uses a stronger mechanical spring structure instead of the traditional friction plate structure to prevent the heavy display from bowing.

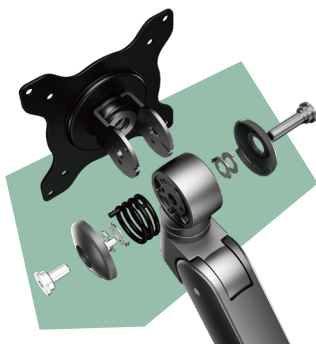

## ► Specifications

Model Name	AM406W (White Color) AM406G (Gray Color)
Design Type	Ergonomic design
Base Type	C-Clamp and Grommet mount
Material Of Monitor Arm	Aluminum Alloy
Fits Screen Size	17"~40"
Weight Capacity	4~12Kg
Max. Height	495mm
Lift Range	250mm
Max. Extension	470mm
Tilt Range	-15° ~ +90°
Swivel Range	-90° ~ +90°
Rotation	360°
Grommet mounting	surface hole from 0.47" wide and up to 3.15" thick
C-Clamp mounting	Desk surface thickness from 0.59" to 3.15"
Interior Structure	Mechanical spring
Compatible Vesa	VESA plate 75 X 75mm or 100 X 100mm
Packaging Dimensions(L x W x H)	408 (L) X 200 (W) X 120 (H) mm
Net weight	2.59 kg
Gross weight	3.16 kg